

Stack Melter Aluminum Melting Furnace

Lindberg/MPH's Stack Melter Aluminum Melting Furnaces provide an energy efficient solution to melting a combination aluminum scrap, sow and ingot.

This stack melter combines three work zones- the Charge Stack, the Melt Zone, and the Holding Zone- in one efficient unit. It is ideal for users with large amounts of scrap, limited space, or the need to change alloys easily. It also helps reduce metal inventory, as well as being easy to clean.

Charge Zone

Optional Loading Mechanisms:

- High Lift Gondolas
- Conveyors

Optional Flue Covers:

- Hydraulic Lift Covers
- Dog House

Melt Zone

Standard stack melters can melt 1500 to 10,000 lbs. per hour. Fuel usages approximately 1150 Btu/lb. Lower aluminum losses than a standard reverberatory furnace.

Hold Zone

Optional Wells:

- Pneumatic Discharge
- Discharge Pump
- Scrap Return
- Degassing
- Recirculation

Can be manufactured to connect to a Launder System.

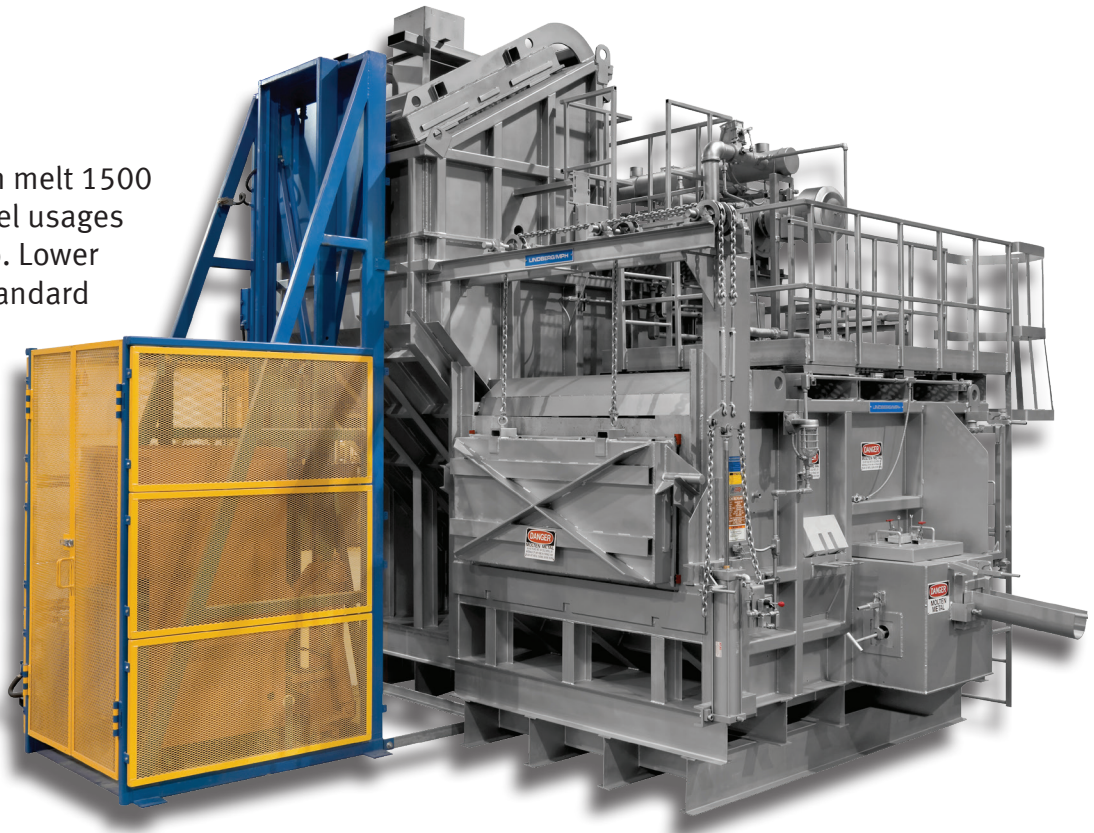

Lindberg/MPH
Phone: (269) 849-2700

P.O. Box 131, 3827 Riverside Road Riverside, MI 49084

• Fax: (269) 849-3021 • lindbergmph@lindbergmph.com

www.lindbergmph.com

LINDBERG/MPH

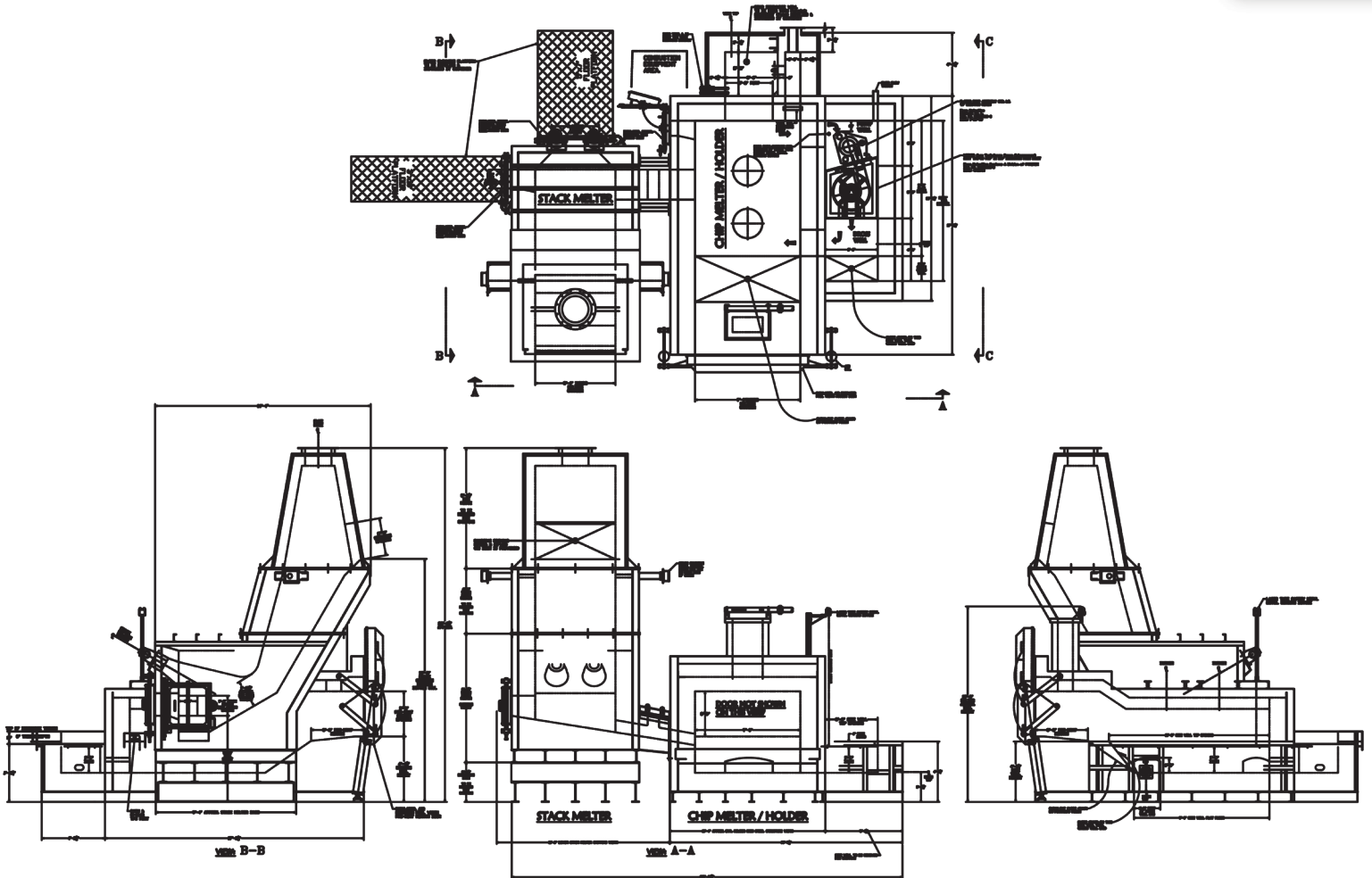

TPS
Lindberg/MPH is a brand of
Thermal Product Solutions, LLC

Lindberg/MPH
Phone: (269) 849-2700

P.O. Box 131, 3827 Riverside Road Riverside, MI 49084

• Fax: (269) 849-3021 • lindbergmph@lindbergmph.com

www.lindbergmph.com